

SDF-50

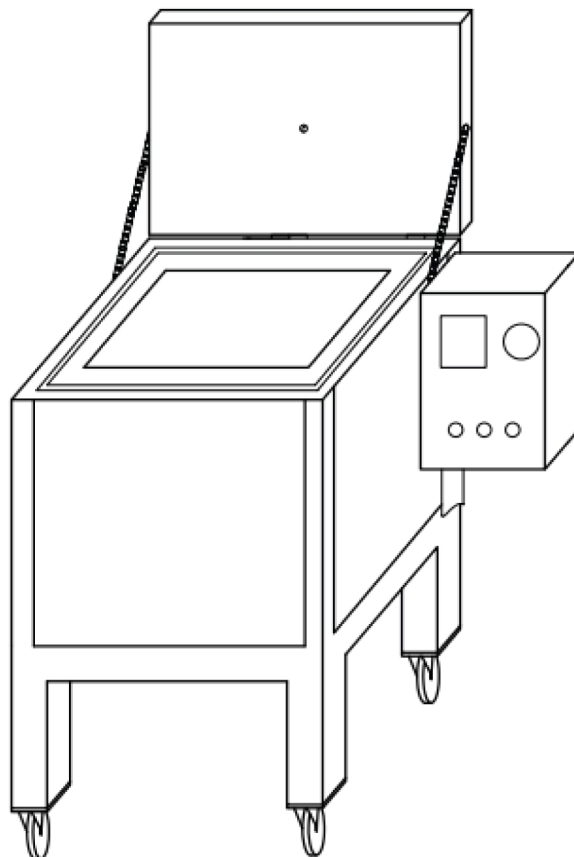

Instruction manual



EU DECLARATION OF CONFORMITY

According to
The Low Voltage Directive 2014/35/EU, entering into force 20 April 2016
The Machinery Directive 2006/42/EC, entering into force 17 May 2006

Type of equipment

Electrode Oven

Type designation

PSE-5, PSE-10, SDE-50, SDE-100, SDE-250, SDF-50, SDF-250

Brand name or trademark

ESAB

Manufacturer or his authorised representative

Name, address, and telephone No:

ESAB Group Inc.

2800 Airport Road, Denton, TX 76207

Phone: 1-800-372-2123

The following harmonised standard in force within the EEA has been used in the design:

EN 60335-2-36 Electrical appliances – Safety Part 2-36: Particular requirements for commercial electric cooking ranges, ovens, hobs and hob elements.

EN 60204-1:2018 Safety of machinery – Electrical equipment of machines – Part 1: General requirements.
--

EN ISO 12100 Safety of machinery – General principles of design – Risk assessment and risk reduction
--

Additional Information:

Restrictive use, Class A equipment, intended for use in location other than residential.

By signing this document, the undersigned declares as manufacturer, or the manufacturer's authorised representative established within the EEA, that the equipment in question complies with the safety requirements stated above.

Date

Signature

Position

2023-02-08

Carlos De Lima

Global R&D Standards Expert

CE 2023

TABLE OF CONTENTS

1 SAFETY 4
 1.1 Meaning of symbols 4
 1.2 Safety precautions 4
2 INTRODUCTION 4
 2.1 Oven use and purpose 4
3 TECHNICAL DATA 5
4 INSTALLATION 5
 4.1 Operation 5
ORDERING NUMBERS 6
WIRING DIAGRAM 7
ORDERING SPARE PARTS 8

1 SAFETY

1.1 Meaning of symbols

As used throughout this manual: Means Attention! Be Alert!



DANGER!

Means immediate hazards which, if not avoided, will result in immediate, serious personal injury or loss of life.



WARNING!

Means potential hazards which could result in personal injury or loss of life.



CAUTION!

Means hazards which could result in minor personal injury.



WARNING!

Before use, read and understand the instruction manual and follow all labels, employer's safety practices and Safety Data Sheets (SDSs).



1.2 Safety precautions



ELECTRIC SHOCK - Can kill

- Do not touch live electrical parts or electrodes with bare skin, wet gloves or wet clothing.
- Insulate yourself from work and ground.
- Ensure your working position is safe.



FIRE HAZARD

- Do not use if the power cord is broken or abnormal temperature variation (not recommended as per manual/factsheet) seen on the oven as it may cause fire.
- Make sure that there are no inflammable materials nearby.



HOT SURFACE - Parts can burn

- Do not touch parts bare handed.
- Allow cooling period before handling or working with the equipment.
- To handle hot parts, use proper tools and/or insulated welding gloves to prevent burns.

2 INTRODUCTION

2.1 Oven use and purpose

The **SDF-50** range of drying and storing ovens are large temperature-controlled cabinets for welding powder flux in a typical industrial set up. They are designed for convenient top loading and bottom removal of welding flux. The easy-to-use digital controller sets and regulates the temperature over a wide range for baking, drying, and storing. Electric heaters embedded inside walls evenly heat the flux without needing agitation or flux turning. Heavy insulation, rugged industrial design, external surfaces electrostatic paint coating, heavy lockable castors make these ovens a great investment for long term easy use.

3 TECHNICAL DATA

	SDF-50
Capacity	50 kg (110 lbs.)
Voltage	3 phase 380-415 V
Frequency	50/60 Hz
Output	3000 W
Temperature	Up to 400 °C (752 °F) Digital thermostat
Outer dimensions (L*W*H, cm)	107 × 67 × 113
Weight (Without electrodes)	110 kg (242 lbs.)

NOTE!

Oven heating temperature can be set from surrounding ambient to 400 °C.

4 INSTALLATION

NOTE!

Make sure that the technical specification on the product corresponds to the electrical supply in your network.

Check the voltage, frequency information and check that there is no fault that will affect the operation of the product.

4.1 Operation

WARNING!

When the oven is not in use, turn the power knob to "O" position and remove power cord plug from electrical outlet.

- Connect oven power cord plug to a power outlet as recommended in the technical information. Make sure the power outlet socket matches the oven power plug type.
- Lock the door after the required amount of flux loaded (up to 50 kg).
- Lock the door.
- On the oven control panel, to turn on the oven change power knob to "I" position.
- Once the power is turned on, depending upon the type of your oven i.e 1Φ one green lamp will glow or 3Φ three green pilot lamps will glow. If the lamps or not glowing, then check the power connection. Refer the below image.

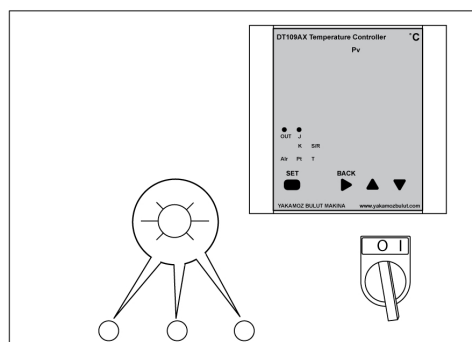
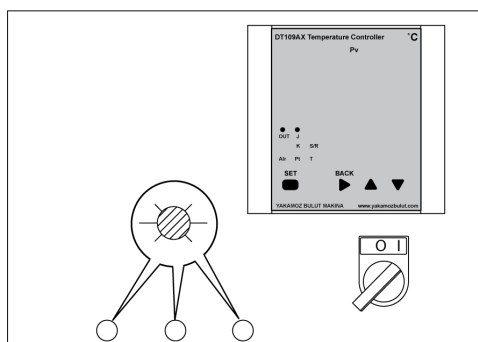

- Setting the desired temperature
 - When the unit is turned on the controller display will show the current temperature and set value.
 - Press and hold the SET button for 2 seconds to set a different temperature. Use up and down keys to reach the desired set temperature. Once the controller read out shows the desired temperature, press SET key again.
 - The oven will now automatically heat up or cool down to the set temperature. The oven will automatically turn off heating when the set temperature is reached. The green lamp will also turn off.
- To use the welding powder, place a 5-gallon bucket underneath the oven spout. Pull the lower arm to discharge powder into the bucket. When the bucket is full or enough flux has been removed, push back the arm.
 - Open and release the release valve on the top to avoid the hot smoke exhaust when opening the front door.

APPENDIX

ORDERING NUMBERS

Ordering number	Denomination	Type	Notes
0700 100 021	Stationary submerged arc welding powder drying oven	SDF-50	Three phase 380- 415 V AC 50/60 Hz

Technical documentation is available on the Internet at: www.esab.com

WIRING DIAGRAM

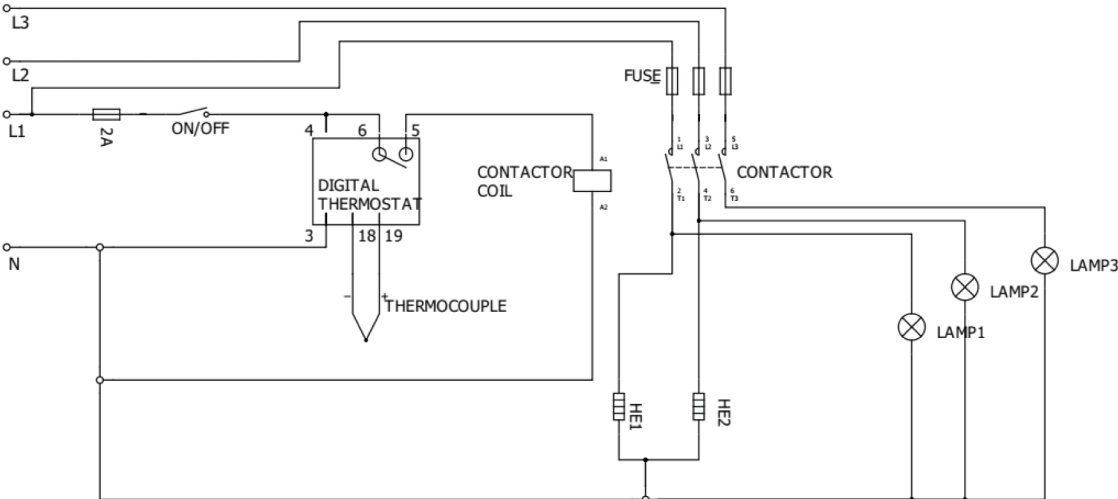

ORDERING SPARE PARTS

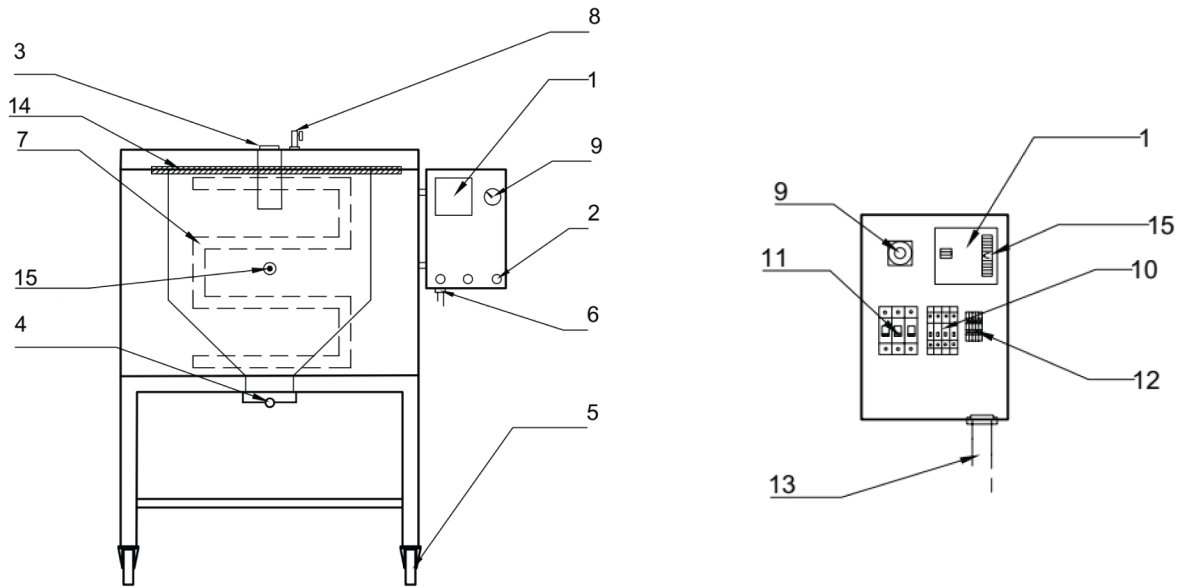

Item no.	Qty.	Ordering number	Description	Notes
1	1	0700 100 002	Digital thermostat	DT-109A
2	3	0700 100 003	Signal lamp	220 V
	3	0700 100 004	Signal lamp	110 V
3	1	0700 100 006	Door handle	
4	1	0700 100 028	Puller arm	
5	2	0700 100 008	Castors without brake	Back
	2	0700 100 009	Castors with brake	Front
6	1	0700 100 031	Cable gland	
7	2	0700 100 011	Heating element	220 V
	2	0700 100 012	Heating element	110 V
8	1	0700 100 020	Air valve	
9	1	0700 100 018	Power switch	
10	2	0700 100 015	Fuse (automatic)	10 A
	1	0700 100 016	Fuse (automatic)	2 A
11	1	0700 100 017	Contactor 220V UNI	220 V
	1	0700 100 023	Contactor 110C UNI	110 V
12	1	0700 100 019	Terminal	
13	1	0700 100 013	Power cable with plug	CEE 5x32 A 400 V plug
	1	0700 100 014	Power cable with plug	110 V
14	1	0700 100 163	Fiberglass wick	SDF-50
15	1	0700 100 165	Thermocouples	



A WORLD OF PRODUCTS AND SOLUTIONS.



For contact information visit <http://esab.com>

ESAB AB, Lindholmsallén 9, Box 8004, 402 77 Gothenburg, Sweden, Phone +46 (0) 31 50 90 00

manuals.esab.com



CE

